

Unipetrol RPA Ltd. Instrumentation & Electrical Equipment Maintenance Section	Temporary Electrical Equipment	N 11 008

The standard is binding for all entities (natural or legal persons) that are involved in installation, operation, maintenance, checks and inspections of temporary electrical equipment within the Záluží Chempark industrial complex. Does not apply to the Litvínov and Kralupy Refinery Unit.

The standard has been developed in cooperation with the Energy Services Department.

Table of Contents:

1. Introduction.....	2
2. The Scope of Validity	2
3. Terminology, Definitions and Terms.....	2
4. Temporary Electrical Equipment.....	5
5. Responsibility Matrix	12
6. Associated Standards and Regulations	13
Appendix A: Request for Connection (Establishment) of TEE.....	14
Appendix B: Examples of Connection to LDS.....	15

Supersedes: N 11 008 of 1. 7. 2010	Standard custodian: Maintenance Support Division	Valid from: 19 January 2018
--	--	---

1. Introduction

In compliance with the ČSN 34 1090 ed.2 standard and The Rules of Operation of the Unipetrol RPA Ltd. Local Distribution System (LDS), the standard stipulates the main principles for installation and operation of temporary electrical equipment in the Záluží Chempark industrial complex.

2. The Scope of Validity

The standard is valid within the Unipetrol RPA Ltd. industrial complex and supersedes the N 11 008 standard of 1 July 2010. It is earmarked for the LDS users, operators of subsidiary distribution systems connected to the LDS either direct or indirect and manufacturers and users of temporary electrical equipment (TEE). It also applies to external organisations providing work for Unipetrol RPA (e.g. TA tasks, capital investment actions, repairs etc.). The duty to take over this standard by the external organisations and to comply with it must be embodied in the contracts on performance or other similar contracts concluded between Unipetrol RPA Ltd. and the relevant contractors.

The standard does not apply to the equipment installed and operated by LDSO; as in this instances special rules apply given by The Rules of Operation of LDS. Moreover, it does not apply to the lv equipment, which is operated within a different regime.

3. Terminology, Definitions and Terms

Company	- Unipetrol RPA Ltd.
Záluží Chempark	- Fenced area under the custody by UNIPETROL RPA Ltd., i.e. the basic plant, petrochemical production facilities, low-temperature storage facilities, wastewater treatment plant, lifting centre and the other offsite fenced and unfenced areas, such as storage facilities and dumping sites that are owned, used or are under custody by UNIPETROL RPA Ltd.
Temporary equipment	- the equipment, that, due to envisaged short lifetime/use, need not be installed so substantially like the equipment earmarked for permanent use.
Construction site switchboard	- type-tested switchboard earmarked for use in construction sites that complied with the verification of the design and verification of the relevant item as per the set of the ČSN EN standards valid at the time of manufacture of the switchboard.
Fixed switchboard	- a switchboard designed for its fixing at its installation place, e.g. on floor or wall, and use at such a point.
Mobile switchboard	- a switchboard so designed that it may be easily moved from one place of its use to another
Construction site	- a space earmarked by the project of organisation of construction of one or multiple objects which constitute a

- construction object. It also includes material and earth storage sites etc., if they serve for the construction and it also includes a production unit technological HW.
- Construction/demolition site facilities - the objects and equipment of temporary nature, which during execution of construction/demolition serve primarily for operation, sanitary and administration purposes of the construction/demolition contractor and which are usually liquidated after completion of the construction/demolition.
- Spaces beyond construction site - administrative & similar spaces of construction site (office rooms, toilets, gathering places, canteens, restaurants, etc.) where general provisions of parts 1 – 6 of HD 60364 apply (*Translators note: HD is unexplained abbreviation. I guess: a sort of some regulation.*).
- Operator - UNIPETROL RPA Ltd., represented by its executive in compliance with the company articles of association. The executive shall ensure the duty to manage properly the means that have been entrusted by the employer and guard and protect the assets against damage, loss, destruction and misuse and shall not to act in contradiction with the justified interests of the employer and shall ensure adoption of timely and effective measures for protection of the assets. For the purpose of fulfilment of associated obligations, he/she determines (through control, organisational and technical standards) the user and the maintaining entity.
- User - Owner or hirer of TEE, works foreman or the head of the organisation executing work for which the TEE is established (as per the 4.3 paragraph). Relevant electrical maintenance technician – in case the TEE is established for the purposes of production and non-production company facilities (as per the 4.2 paragraph). He/she is responsible for operation and for compliance with the conditions for safe and reliable operation of TEE in compliance with the advice and regulations earmarked for its use, running and operation. Upon his/her request, the TEE is established beyond the workplaces earmarked for implementation of capital investment projects, where the co-applicant is the employee of the organisation ensuring construction supervision and this employee also assumes responsibility. In compliance with the 4.3 paragraph and for the purpose of this standard, a supervision-level employee of the external organisation executing the activities for which the TEE is being established is also the user.
- Maintaining entity - A director of a technical section or service section, a maintenance section head, industrial complex custody department head, relevant electrical maintenance technician or an employee assigned otherwise, who is responsible for the technical condition of the determined individual groups of tangible assets, including maintaining, repairs, inspections and tests. In compliance with the paragraph 4.2,

	for the purposes of this standard, this function can be performed for the user by a contractor's employee of electrical discipline.
Contractor (el. discipline)	- natural or legal person wielding certification for assembly, repairs and maintenance of electrical equipment (section 6, subsection 1, paragraph b) of the 174/1968 Act) as well as valid trade licence. He/she carries out the activities for the company and the other external organisations on the basis of relevant contracts.
Contractor (general)	- natural or legal person chosen for commission implementation
Inspection of el. equipment	- set of actions through which the status of electrical equipment in terms of safety is discovered by visual inspection, measurement and testing. The inspection includes development of inspection report.
Inspection technician	- natural person authorised for execution of tests and inspections of electrical equipment on the basis of expert-authorisation of the type and scope as issued by CRTI Prague.
ČSN	- Czech Technical Standard (<i>Translator's note: The Czech abbreviation will be maintained hereinafter.</i>)
CRTI	- Czech Republic Technical Inspectorate
LDS	- local distribution system of electricity both within the company fence and beyond it, to which the licence of electricity distribution applies and which is operated as per the 458/2000 Act and its implementation regulations.
LDSOR	- LDS operating rules (www.unipetrolrpa.cz .)
LDSO	- LDS operator
LDSO representative	- an employee assigned by LDSO (LDS Section employee – tel. 2510)
LDS user	- entity using the LDS services
Connection point	- point of connection of TEE to LDS or to company-owned distribution equipment
Contract	- Contract
TS	- company Technical Section
ESD	- Energy Services Department (electricity supplier)
TEE	- temporary electrical equipment
Short-term test operation	- energising the equipment to check/measure the impedances of loops & RCBO's
EE	- external effects

4. Temporary Electrical Equipment

4.1 General

4.1.1 The standard applies to the following:

- equipment established as replacement for failed electrical equipment,
- temporary equipment of technological HW,
- portable & transported equipment,
- equipment at construction/demolition sites at capital investment projects & divestment actions,
- temporary equipment used at maintenance activities,
- temporary equipment for contract-based activities.

This equipment can be connected via cables, cords & movable connections, as per the 4.1.7.1 and 4.1.7.2. requirements.

4.1.2 The TEE can only be established in cases as per 4.1.1. and only for unavoidable duration. It must be removed immediately after the reason for its establishment ceased to exist.

4.1.3 The request for its permanent switching off and removal must be announced to the LDSO representative and to the relevant maintaining entity of the electrical equipment.

4.1.4 The TEE is established for maximum duration of 6 months and in case of the need of longer operation, it is considered to be reinstated equipment. It is necessary to carry out initial inspection and carry out regular inspections of the TEE.

4.1.5 The TEE can only be used under stipulated working and operational conditions and for the purpose for which it has been manufactured or established and it must be maintained in good technical condition, which complies with the relevant standards and regulations.

4.1.6 It is forbidden to establish TEE in explosion-and-fire-potential environments. If this cannot be complied with, it is necessary to go by the 465 Directive.

4.1.7 The following general provisions apply for all types of equipment:

- The TEE can only be connected and disconnected by the contractor wielding authorisation for assembly, repairs, maintenance and inspections of electrical equipment, whose performance within the company has been approved in the relevant contracts.
- The contractor wielding authorisation for assembly, repairs, maintenance and inspections of electrical equipment and who is included in the company vendor list can only establish and remove the TEE for external organisations performing within the company industrial complex.
- The TEE used within the company industrial complex must comply with the requirements/conditions as per the ČSN 34 1090 standard, as amended, (on TEE of **construction and demolition sites** and similar spaces), and it must also comply with the following:

- **Mobile or transported cabins**

In case of connecting mobile or transported cabins, it is necessary to go by:

- ČSN 33 2000-7-717 ed.2: Dedicated Equipment and Equipment Situated in Special Objects – Mobile or Transportable Units”.
 - ČSN 33 2000-7-704, as amended, Electrical Equipment at Construction Sites and Demolition Sites
- The TEE **at construction & demolition sites** within the company industrial complex must also comply (**in general, including serviceable cables**) with:
 - ČSN 33 2000-7-704 ed.2 „Electric Equipment at Construction/Demolition Sites”
 - For energising/connection of TEE **at construction/demolition sites construction site switchboards can be used** manufactured and tested as per:
 - ČSN EN 60439 - 4 ed.2 „Special Requirements for Construction Site Switchboards “
(abolishment date: 20.12.2015)
OR
 - ČSN EN 61439-4 „ Special Requirements upon Construction Site Switchboards (ACS) “
 - For energising/connection of TEE **beyond construction site** mobile switchboards can be used manufactured and tested or verified as per:
 - ČSN EN 60439-1 “Type-Tested and Partly Type-Tested Switchboards”
OR
 - ČSN EN 61439-1 (ed.2) „General Provisions“
together with
ČSN EN 61439-2 (ed.2) „Power Transformers“
 - For energising/connection of TEE **beyond construction site** fixed switchboards can be used manufactured and tested or verified as per
 - ČSN EN 61439-1 (ed.2) „ General Provisions “
together with
ČSN EN 61439-3 “Distribution Boards Earmarked for Operation by Laymen (DBO)”
OR
 - ČSN EN 60439-3 “Special Requirements for LV Switchboards Earmarked for Installation in Places Accessible for Layman Operators. Distribution Boards”
 - TEE must be provided with main switch marked with plate, or a place for possible switch-off in case of danger must be determined and this place must be marked with a plate.
 - During idle time the TEE must be switched off. This does not apply for TEE established as replacement for failed electrical equipment.
 - TEE must be regularly supervised by the user or by an employee assigned by the user, whilst the employee must wield expert authorisation of a familiarised

person with enhanced qualification as per the 50/1978 Edict. Regular supervision is: often and careful checks of the entire TEE on-the-run, immediate remedy of discovered faults etc. Before the TEE commissioning, the assigned employee (user), in cooperation with the maintaining entity, will determine (taking into account the local conditions) the frequency of the checks. LDSO supervises the equipment operation in terms of compliance with LDSOR with respect to the LDS safety and reliability. If it is discovered that LDSOR are breached or the maintaining entity's conditions are breached, the TEE will be disconnected by the maintaining entity or by the LDSO.

- 4.1.7.1 The requirements on laying cables, cable routes/distribution running on surface and on structures. All cables must be flexible conductors of the H07 RN-F type, or similar (attrition-resistant and water-resistant).
- Cables must be so secured so that they do not get into contact with hot surfaces or to their proximity, unless such types of cables are used that are earmarked for such conditions.
 - Cables must not lie on the ground where their damage is possible (during usual use of the area) or on such surfaces that endanger their jackets (sharp articles, sharp gravel etc.).
 - Cables must not lie at the places where they would pose obstacles.
 - Cables must not be laid across frequently used places, wet or muddy workplaces, across such workplaces where heavy articles are transported or where earthwork is often carried out, across such places where gravel or construction material is handled or heavy machinery is used.
 - Cables must not be laid across places where easily flammable or explosive substances occur. In such places where the above dangers occur, movable connections or leads must be provided with protective covers, or protective casing, or via proper routing. Metal hoses must not be used for mechanical protection.
 - At traffic crossings (pathways and roads to the relevant workplace) the movable inlets or cables must be hung in safe height or buried in the ground and properly and reliably protected against mechanical damage (e.g. by installation into a crossing bridge, into sufficiently strong groove in ground, into sufficiently mechanically-strong protective tube etc.).
 - If cables are installed vertically, without auxiliary supports, and are inaccessible and it is unlikely that they might be damaged or might move, they must be fixed at the upper end as per the requirements of standards. The unsupported vertical length of cable must not be longer than 5 metres.
Cables and flexes must be installed in such height and in such a manner so that they may not cause obstacles during routine use of the relevant space and the supports must be in such distances from one another so that their stress might not exceed the acceptable limit.
 - If span is longer than 5 metres, the cable or flex must be secured at installation place against shift, and if the span is longer than 15 metres, carrier rope or suspension cable must be used.
 - At hanging of movable cables onto supports, proper supports must be used. The supports must be sufficiently mechanically strong and resistant and properly modified. Fixing (anchoring) of cables and flexes must be reliable and carried out in suitable manner.
 - Cables running beyond cable routes must be marked with information plates reading: "Attention! – Electrical Equipment".

- If movable cables run on scaffold, the scaffold must be properly earthed.
- Movable connections between the connection point and the TEE must be compact (one (uninterrupted) cable).

4.1.7.2 Requirements concerning laying the cables onto ground

- At laying the cables onto ground it is necessary to go by the LDSOR and the relevant ČSN standards.

4.1.8 Before commissioning of TEE the staff operating the equipment must be provably advised by the user or an employee assigned by the user (or contractor's representative) about the following:

- the purpose of the equipment,
- equipment safety,
- where the main switch is or where the point of prospective switch-off of the TEE is,
- the necessity to switch off the TEE if it is idle, in case of failure or in case of danger.

4.1.9 TEE may not be relocated without consent granted by the LDSO and the relevant electricity maintaining entity.

4.1.10 When the reason for establishment of TEE ceases to exist, the equipment must be removed at the establishing entity's expenses.

4.1.11 The user must notify the maintaining party, the UNI RPA and the LDSO on his intention to cease the utilisation of TEE at least 5 working days before disestablishment of the TEE.

4.1.12 For each TEE, it is necessary to evaluate the EE and the requirements on the equipment design ensuing from the EE (ČSN 34 1090, as amended)

- If there is valid protocol on determination of EE for the space where the TEE is to be placed, it is necessary to evaluate if the equipment aggravates or does not aggravate the existing effects.
- If no protocol on determination of EE exists or if installation of the TEE aggravates the existing EE, the user, or a person assigned by him, must develop a protocol for the TEE.

4.1.13 The procedure of connection under voltage for the purpose of inspection.

- At the presence of IT to:
 - check the integrity of protective conductors R_{PE}
 - check the insulation resistance of TEE R_{ISO}
- If the R_{PE} and R_{ISO} values comply with the requirements of standards, it is possible to start a short test operation of the TEE to check/measure the impedances of failure loops (Z_{sm}) and the functions of RCBO's (actuating currents $I_{\Delta N}$, actuating time t_{Δ} and contact voltage U_C). After the measurements are carried out, the TEE will be disconnected from voltage.
- If the measured values comply with the requirements of standards, it is possible to develop an inspection report, on the basis of which the TEE will be commissioned.

4.2 Providing TEE for the Company's Production and Non-Production Facilities

4.2.1 TEE is provided:

- as a replacement for failed electrical equipment,
- as temporary equipment of technological HW and temporary energising of objects,
- as portable and transportable equipment for the purposes of production and energising for non-production electricity consumption

4.2.2 The operator must ask in writing the relevant electrical maintenance technician for permit to establish TEE. In the request the operator must state this intelligence as a minimum:

- The requested date of connection of TEE and the envisaged date of removal of TEE.
- The TEE type (mobile container, construction site switchboard etc.)
- The purpose of the TEE (welding, annealing, company non-production facilities, etc.)
- The requested protection
- The requested duty
- The site where the TEE will be placed
- The contact person, including the contact data

4.2.3 The TEE can only be provided after consent in writing by a person responsible for the electrical equipment (Relevant el. maintaining entity in whose competency the connection point is. He will express his consent in the answer to the written operator's request.) and for the period of 6 months maximum. If the TEE cannot be removed, a repeated consent by the person responsible for electrical equipment must be granted and inspection must be carried out.

4.2.4 If the TEE is connected from LDS or if the equipment connected via cable or flex line has energy input higher than 5 kW, the LDSO representative's consent shall be additionally requested.

4.2.5 The TEE is installed and checked by contractor on the basis of the approved operator's request. Before commissioning, the relevant contractor shall ensure execution of initial inspection for connection and regular inspections at the TEE.

The report on the initial inspection must be submitted to the maintaining entity or to the LDSO representative (see 4.2.4) before the TEE is commissioned.

4.3 Providing TEE for the Purposes of External Companies Operating within the Company's Industrial Complex

4.3.1 The TEE is provided for:

- for the purposes of maintenance activities,
- for the purposes of establishing construction sites
- for capital investment project implementation and activities carried out on the basis of contracts.

4.3.2 For request for permit to establish TEE, the user shall use "The Request for Connection of TEE", whose pattern is to be found in Appendix A.

- 4.3.3 TEE can only be established with written consent granted by LDSO representative and relevant el. maintaining entity in whose competency the connection point is (he will grant his consent in appendix to the request No. 1). The technical options, the manner of connection and measurement of electricity shall be negotiated with the LDSO representative and the relevant maintaining entity in advance (see LDSOR).
- 4.3.4 TEE is installed and checked by contractor on the basis of the approved user's request.
- 4.3.5 TEE – construction site switchboard must be provided with measurement equipment (electricity meter or measurement current and voltage transformers) for commercial measurement of consumed electricity (this does not apply if measurement equipment is situated in the connection point – LDS distribution transformer station). The used measurement equipment (electricity meter or measurement current and voltage transformers) must have assigned brand of approved type, specified precision class (see LDSOR) and must be verified – verification sheet or official mark.
- 4.3.6 Before TEE commissioning the contractor or user shall submit to the relevant el. maintaining entity (in case of direct connection to LDS, also to the LDSO representative) the following inspection reports:
- with the TEE provided with plug (where no modifications are needed): regular equipment inspection report
 - with the TEE where connection modifications are needed: regular equipment inspection report and the initial inspection of lead-in.
- 4.3.7 Before commissioning, the TEE user must conclude a contract on connection and supply of electricity with assigned JESL (*Translator's note: unexplained abbreviation*) employee (tel. 3639).
- 4.3.8 Any increase of the energy input agreed in the request must be negotiated with the LDSOR representative.

4.4 Operation of TEE

- 4.4.1 The operated TEE must be registered. Registration of approved TEE and TEE removal is carried out by LDSO and the el. maintaining entities in whose competencies the connection points are – in the scope as per paragraphs 4.2 and 4.3.
- 4.4.2 The TEE user is responsible for the following:
- justification of establishment of TEE,
 - submitting request for connection,
 - conclusion of contract on connection and supply of electricity,
 - safe operation of TEE,
 - notifying the LDSO and the el. maintaining entity on cessation of the reason for establishing TEE,
 - provable instruction/training of the employees on the rules for safe use of TEE.
- 4.4.3 The user is responsible for the following:
- registration of TEE,

- compliance with the stipulated time of establishing TEE.

4.4.4 The contractor (generally)/user of TEE is responsible for the following:

- enabling reading of electricity meter values – before take-off, during take-off and at cessation of take-off,
- execution of regular checks and inspections of TEE,
- instruction of the employees operating the equipment,
- assigning employees for supervision over TEE,
- submitting verification of the measurement equipment as per 4.3,
- submitting the initial inspection report of connection of TEE and reports on regular inspections to the maintaining entity representative,
- reinstating the site to the original condition after removal of TEE, if the reason for its operation ceases to exist,
- identification of TEE with information label bearing the company's contact data and the contact data of the person responsible for TEE, whilst the label must be in weather-proof design.

5. Responsibility Matrix

Activity	Operator	Maintaining entity	LDSO	Contractor	User	Reference
Determination of electrical equipment maintaining entity	R	C	I		I	Chap. 3
Determination of electrical equipment user	R		I		C	Chap. 3
Authorisation to approve establishment of TEE		R	R		C	par. 4.2.3 par. 4.3.3
User's request for establishing TEE		C	I		R	par. 4.2.2 par. 4.3.2
Justification of establishing TEE		C	I		R	par. 4.4.2
Conclusion of contract on electricity supply		C	I		R	par. 4.3.7
Ensuring TEE inspections		C	I	R	R	par. 4.2.5 par. 4.3.6
Submission of inspection reports to the maintaining entity & LDSO		I	I	R	R	par. 4.4.4
Assigning staff for supervision over TEE		I	I	R	R	par. 4.1.8 par. 4.4.4
Instruction of staff on TEE operation		I		R	R	par. 4.1.8 par. 4.4.4
Responsibility for safe TEE operation				R	R	par. 4.4.2
Registration of TEE		R	R		C	par. 4.4.1 par. 4.4.3
Request for permanent switch-off & notification on cessation of electricity take-off		I	I		R	par. 4.1.2 par. 4.4.2
Removal of TEE once the reason for its operation ceased to exist		C	I	R	C	par. 4.4.4

R - responsible, C - cooperates, I – is informed

6. Associated Standards and Regulations

Wherever the company N11008 standard refers to acts, edicts, technical regulations (standards) etc., the references are always made to the valid wording of such documents, or documents valid at the time of manufacture of TEE.

65/1965 Act	- Labour Act, as amended
458/2000 Act	- Energy Act
174/1968 Act	- (on national expert-supervision over occupational safety)
LDSOR	- LDS Operation Rules (www.unipetrolrpa.cz, Intranet).
73/2010 Edict	- (on determination of law-stipulated technical equipment, its class & group classification and detailed conditions of its safety)
50/1978 Edict	- (on expert-authorisation in electro-technical industry, as amended with the 98/1982 Edict)
ČSN 33 1500 (incl. Z1 - Z4)	- (on inspections of electrical equipment)
ČSN 33 2000-3	- (on determination of the basic characteristics) (abolished on 1.5.2011)
ČSN 33 2000-4-41 ed.2 (+ Z1)	- (on lv el. installations) - Part 4-41: (Protective measures for ensuring safety – protection against injury by el. current)
ČSN 34 1090 ed.2	- (regulations for TEE)
ČSN 33 2000-7-704 ed.2	- (El. equipment at construction/demolition sites)
ČSN EN 60439-1	- (lv switchboards). Part 1: (Type-tested & partly type-tested switchboards)
ČSN EN 60439-3	- (lv switchboards) Part 3: (Special requirements for lv switchboards earmarked for installation at sites. accessible for layman operators. Distribution boards.)
ČSN EN 60439-4	- (lv switchboards) Part 4: (Special requirements for construction site switchboards)
ČSN EN 60439-4 ed.2	- (lv switchboards) Part 4: (Special requirements for construction site switchboards)
ČSN EN 61439-1 ed.2	- (lv switchboards) - Part 1: (General provisions)
ČSN EN 61439-2 ed.2	- (lv switchboards) - Part 2: (Power switchboards)
ČSN EN 61439-3	- (lv switchboards) - Part 3: (Distribution boards earmarked for operation by laymen (DBO))
ČSN EN 61439-4	- (lv switchboards) - Part 4: (Special requirements on construction site switchboards (ACS))
ČSN 33 2000-7-717 ed.2(+OPR1)	- (on dedicated equipment and equipment situated in special objects – Mobile or transportable cabins)
ČSN 34 0350 ed.2	- (on safety requirements concerning movable cables & flex lines)
ČSN EN 50565-1	- (electric cables) - (Advice for use of cables with nominal voltage up to 450/750V (U ₀ /U) - Part 1 (General advice)
ČSN EN 50565-2	- (electric cables) - (Advice for use of cables with nominal voltage up to 450/750V (U ₀ /U) - Part 2 (Specific

	guidance for the types of cables associated with EN 50525)
465 Directive	- Work Permits
N 11 006	- Rules concerning Electrical Equipment
N 11 012	- Unipetrol Electricity Standards
CRTI Position	- TIGR/34084/2017

Appendix A: Request for Connection (Establishment) of TEE

The request can be downloaded here: www.unipetrolrpa.cz

<http://www.unipetrolrpa.cz/cs/sluzby-areal/chempark-zaluzi/lokalni-distribucni-soustava/Stranky/default.aspx>

- **The applicant as per paragraph 4.3 shall fill in:** the entire request for connection, incl. the Appendix 1 of the request
- **The el. maintaining entity in whose competency the connection point is shall fill in:** Appendix to the Request No.1 – Siting and the Manner of Connection of Electric Connector and Approval by the Relevant El. Maintaining Entity

Appendix B: Examples of Connection to LDS

EXAMPLES OF CONNECTION TO LDS

1. Direct to LDS

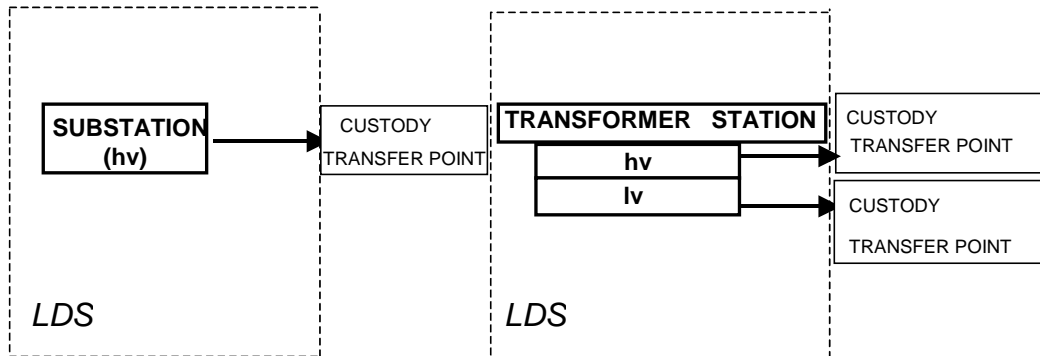

2. Indirect to LDS

(to equipment owned by Industrial Complex Custody Division or production facilities of Unipetrol RPA)

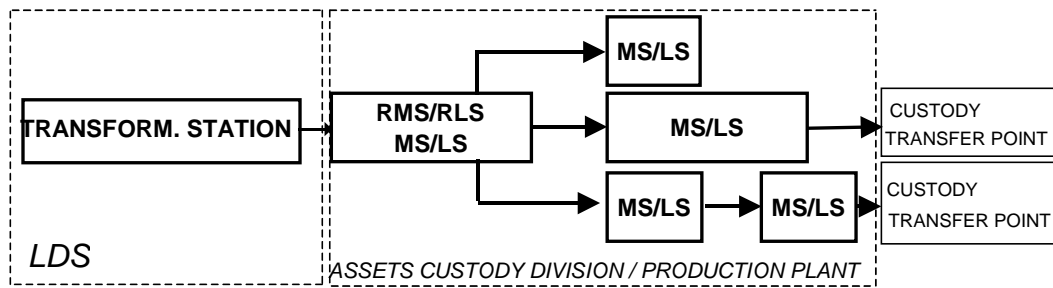

- | | |
|--------------------------|------------------------------------|
| RMS - | Round motor switchboard 500 V |
| RLS - | Round lighting switchboard 400 V |
| MS | Motor switchboard 500 V |
| LS - | Lighting switchboard - 400 V |
| CUSTODY TRANSFER POINT - | Point of connection to switchboard |

 English translation by Ing. Zbyněk Zeman, translator certified by the University of Cambridge (CPE – Certificate of Proficiency in English) and by the Czech Republic authorities (State Examination in English & Official Court Translator) & EC translator